

## Specifications

| Items   | Unit           | SEM655D                 | Items                                 | Unit | SEM655D      |
|---|----------------|-------------------------|---------------------------------------|------|--------------|
| <b>Main Specifications</b>                    |                |                         |                                       |      |              |
| Rated Load                                    | kg             | 5,000                   | Reverse 2                             | km/h | 15.2         |
| Operating Weight with Standard Bucket         | kg             | 16,500                  | Reverse 3                             | km/h | 23.5         |
| Bucket Capacities                             | m <sup>3</sup> | 2.7-4.5                 | Reverse 4                             | km/h | 41.3         |
| STD GP Bucket Capacity                        | m <sup>3</sup> | 3.0                     | <b>Implement Hydraulic System</b>     |      |              |
| Overall Dimensions L*W*H (mm)                 | (mm)           | 7,975×2,855×3,482       | Raise                                 | s    | 5.14         |
| <b>Operating Specifications</b>               |                |                         |                                       |      |              |
| Breakout Force (GRD) ---Tilt @System Pressure | kN             | 177                     | Total                                 | s    | 9.6          |
| Max. Drawbar pull force@ Fwd 1st              | kN             | 161                     | Implement Pressure                    | Mpa  | 17           |
| Minimum Turning Radius---Centerline of Tire   | (mm)           | 5,772                   | <b>Brakes</b>                         |      |              |
| <b>Engine</b>                                 |                |                         |                                       |      |              |
| Model   |                | WDEC WD10               | Service Brake                         |      | Disk/Caliper |
| Emission                                      |                | Nation II               | Parking Brake                         |      | Shoe/drum    |
| Rated Gross Power                             | kW             | 154                     | <b>Steering</b>                       |      |              |
| Bore x Stroke                                 | (mm)           | 126×130                 | Steering Angle (Lift/Right)           | (°)  | 38±1         |
| Displacement                                  | L              | 9.726                   | <b>Axle</b>                           |      |              |
| Peak Torque/Speed - Gross                     | N.m/rpm        | 975/1200-1400           | Rear - Oscillating +/-                | (°)  | ±11          |
| <b>Transmission</b>                           |                |                         |                                       |      |              |
| Transmission Type                             |                | Countershaft Powershift | <b>Tires</b>                          |      |              |
| <b>Travel Speed</b>                           |                |                         |                                       |      |              |
| Forward 1                                     | km/h           | 7.9                     | Size                                  |      | 23.5-25      |
| Forward 2                                     | km/h           | 15.2                    | Type                                  |      | Bias         |
| Forward 3                                     | km/h           | 23.5                    | Layer                                 |      | 16           |
| Forward 4                                     | km/h           | 41.3                    | Textured Type                         |      | L3/E3        |
| Reverse 1                                     | km/h           | 7.9                     | <b>Service Refill Capacities</b>      |      |              |
|   |                |                         | Fuel tank                             | L    | 260          |
|   |                |                         | Hydraulic Tank                        | L    | 150          |
|   |                |                         | Cooling System                        | L    | 38           |
|   |                |                         | Engine Lubricating Oil                | L    | 23           |
|   |                |                         | Transmission Oil                      | L    | 55           |
|   |                |                         | <b>Differentials and Final Drives</b> |      |              |
|   |                |                         | Front                                 | L    | 26           |
|   |                |                         | Rear                                  | L    | 26           |

## Dimension

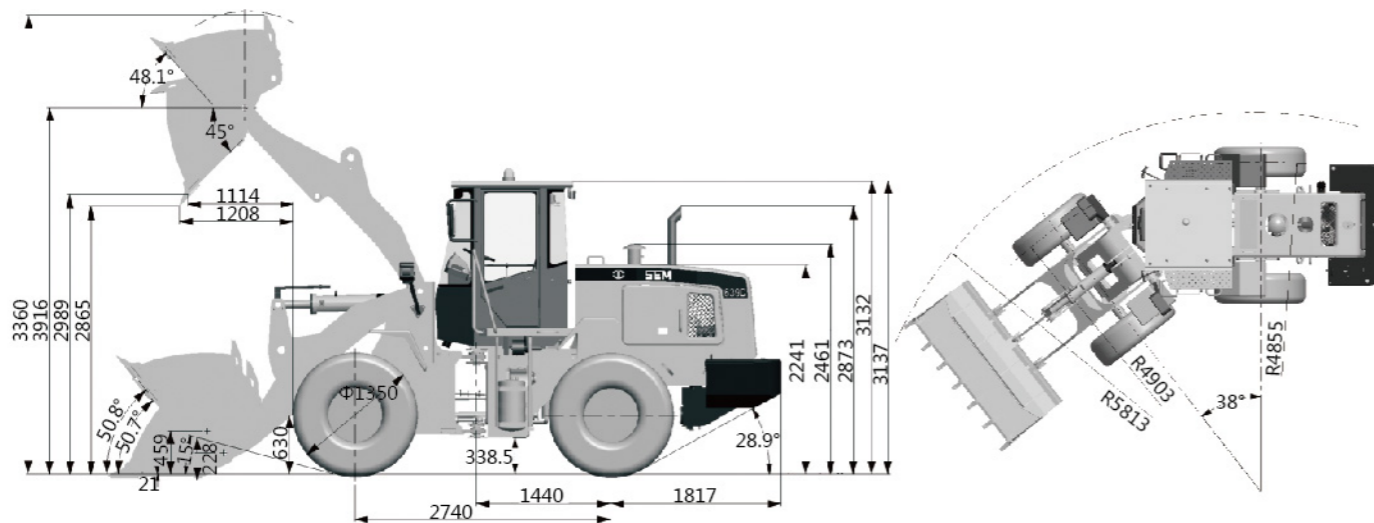

### Caterpillar (Qingzhou) Ltd.

Materials and specifications are subject to change without notice. Featured machines in photos may include optional equipment. See your SEM dealer for available options.

© 2015 Caterpillar (Qingzhou) Ltd. SEM, its respective logos, trade dress as well as corporate and product identity used herein, are trademarks of Caterpillar (Qingzhou) Ltd. and may not be used without permission. All rights are reserved.

#### DEALER NAME

Address:  
Telephone:  
Fax:  
Email:  
Website:

Dealer Logo Area

# SEM655D Wheel Loader



\* Featured machines in photos may include optional equipment.

## SEM655D

### Product Advantage

- **Reliability:** All structures undergo rigorous design and analysis methods. These include Finite Element Analysis (FEA), strength and fatigue life analysis, and on machine stress analysis (OMSA). These methods ensure enhanced structural life
- **Higher Efficiency:** Design utilizes world class hydraulic pumps and components, to deliver reliability and durability
- **Comfort:** Cab working space increases 30% and utilizes Luxurious interior decorative and suspension seat

[Http://www.semmachinery.com](http://www.semmachinery.com)



## Large Cab

### [ Operation Station & Hood ]

- Cab working space increase 30%, use Luxurious interior decorative and suspension seat
- Hood increase 30% open place for easy daily maintenance and repair; Rear hood can open easily
- SEM655D has wider cabin left side can put a bag more than 400mm
- Suspension seat with handle and seat belt
- Both side of the cabin door the glasses can slide up and down



## Powertrain

### [ Features ]

- Industry Leading Powertrain
- Countershaft Transmission, longer service intervals than planetary
- Torque Converter Insolated with Transmission
- High efficiency torque converter
- Meritor axles, more reliable, more quicker

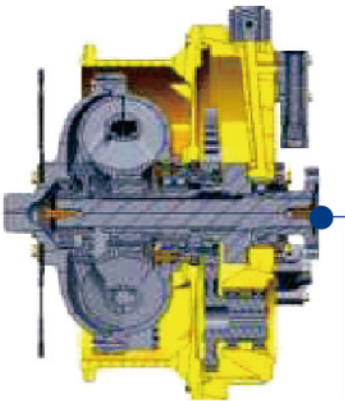
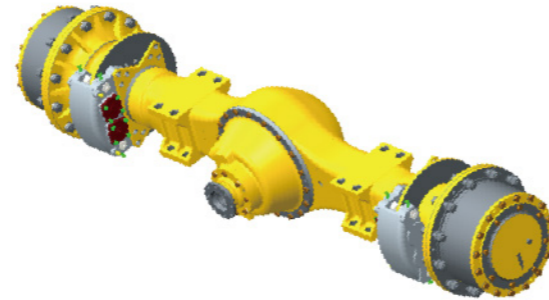

### [ Uniaxial Output ]

### [ Single Stage Three Element Torque Converter ]

- Compared with twin-turbine type, Single stage 3 element TC is much more reliable, the transmission efficiency can achieve to 85%, higher than twin-turbine transmission system, and the traction force is larger
- Adopts the Separate Assembly Structure, avoid different vibrational frequency of engine and transmission box, reduce the maintenance. Planet type torque converter and transmission use one-piece design, the structure is complicated

### [ Meritor Heavy-Duty Drive Axle ]

- Standard 28-ton axle, 8 teeth design, use large module gears, industry competitors usually adopts 26 tons, 7 teeth design, bearing capability increased 8%
- Hub reductions adopts 4 planetary gears, compare with industry competitors' 3 gear design, the load distribution is much more average, and life is longer

### [ Split type gear ring ]

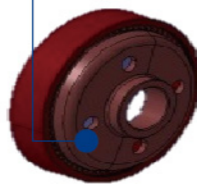

### [ 8 teeth main bevel reduction gear ]

## Hydraulic System

### [ Features ]

- Design utilizes world class hydraulic pumps and components, to deliver reliability and durability
- Industry leading implement valve and high-pressure oil tube produced by Caterpillar
- The hydraulic cycle time only has 9.6s, work efficiency is higher
- The pilot system STD Pressure oil filter to keep dust away other Chinese competitors don't have
- Dual pump flow sharing technology

### [ Dual pump flow sharing system ]

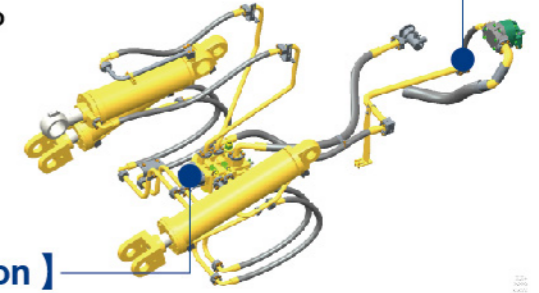

### [ Pilot Operation ]

### [ Dual Pump Flow Sharing Technology ]

- When the steering system does not need the hydraulic pressure & flow, the priority valve directs this energy to be utilized by the hydraulic implement system. This saves fuel consumption
- Reduced the main pump displacement, large flow-sharing is efficiency and energy-saving, which can reduce the engine load

### [ Dual Pump Flow Sharing Technology ]

- Precision control joystick ensures excellent modulation, to control the boom and bucket functions, high reliability, not easy to stop the valve
- Comfortable operation, save time and strength

## Cooling System

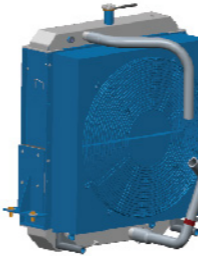

### [ Cooling Cores ]

- Adopts triple module all aluminum radiator, separately cools engine cooling liquid and hydraulic oil to realize 43 degree work environmental temperature, which exceeds the industry standard (40 degree)
- Optional bronze material high-temperature water tank which can satisfy 50 degree work environment

### [ High Durability and Reliability Frame and Structure ]

- Plate & fin type high pressure resistance cooler design, the using life is higher than the usual tube & fin
- Radiator mounting on the shock pads, to ensure cooling system's reliability under the severe turbulence work conditions
- Assemble the sealing plate between radiator and engine hood, make sure the cooling effect

## Linkage & Structure

- Tapered Roller join two frame together more stable and higher carry ability
- All structures undergo rigorous design and analysis methods. These include Finite Element Analysis (FEA), strength and fatigue life analysis, and on machine stress analysis (OMSA). These methods ensure enhanced structural life
- All structures utilize world class welding techniques, equipment and quality controls, to ensure low stress and long component life

