

**Patent Pending
International (PCT) Application No. PCT/EP2022/083516**

REVISIONS				
ZONE	REV.	DESCRIPTION	DATE	APPROVED
	A	INITIAL ISSUE	01/02/2022	MG
	B	INTERNATIONAL PATENT APPLICATION NUMBER ADDED	10/01/2023	MG

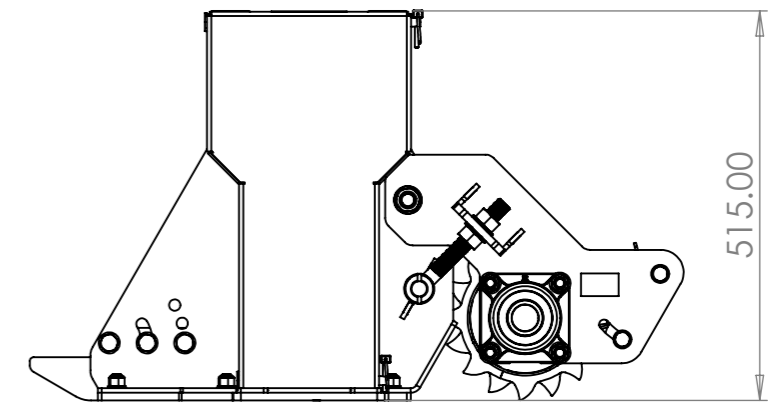
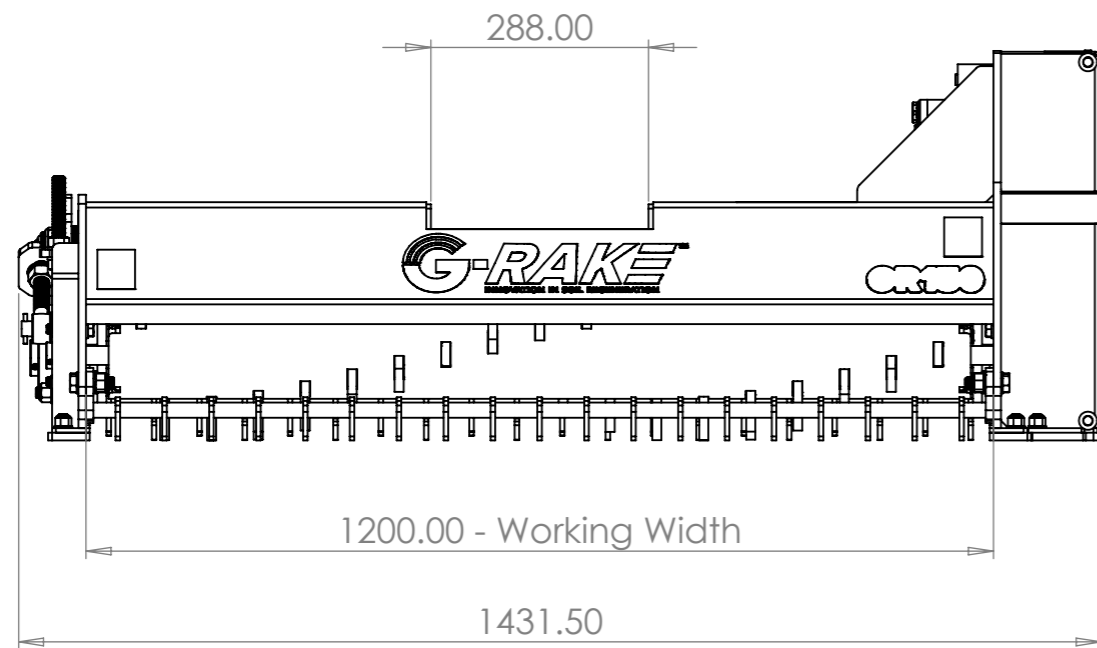
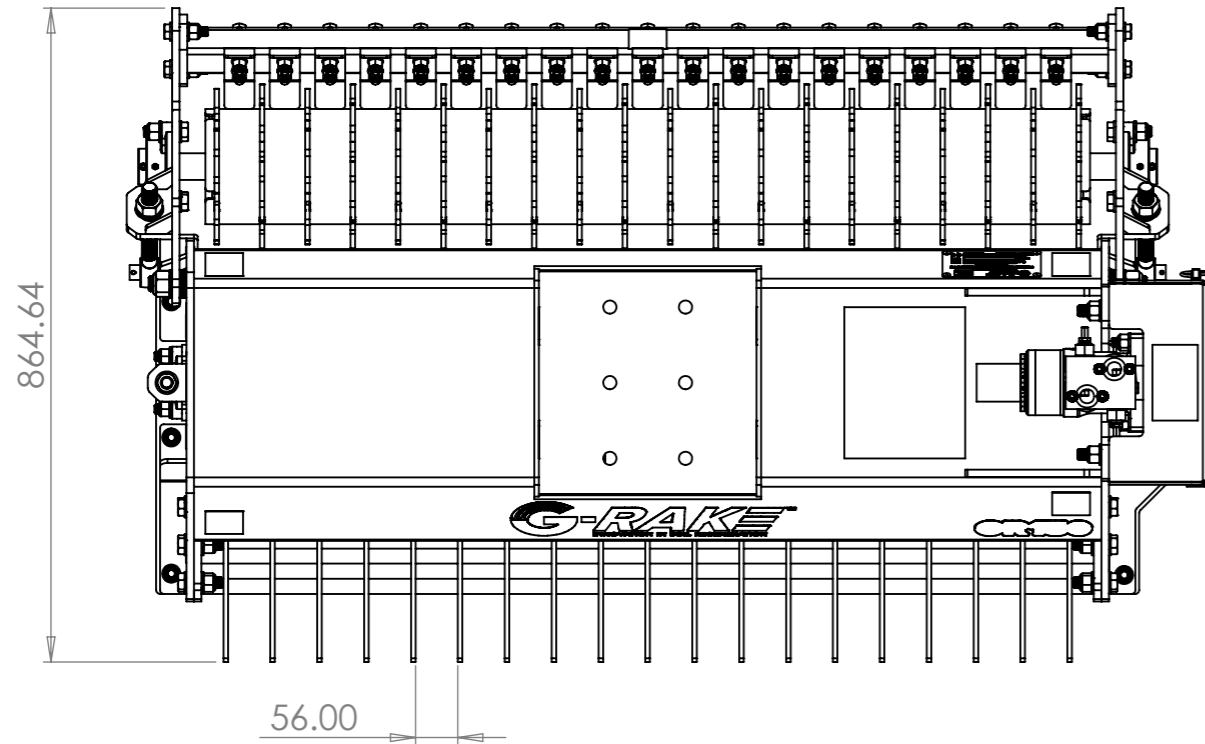

G-RAKE LIMITED
7 SLIEVEGRANE ROAD, DOWNPATRICK,
NORTHERN IRELAND, BT30 6PF
TELEPHONE: 02844617777
EMAIL: INFO@G-RAKE.CO.UK

PRODUCT:
G-RAKE GR120

PART NUMBER:
GR120

FINISH:
SEE PART AND ASSEMBLY
DRAWINGS

SERIAL NUMBER:
GR120XXXX

MATERIAL:
SEE PART DRAWINGS

DO NOT SCALE DRAWING
DEBUR/BREAK SHARP EDGES
REMOVE LASER/FOLDING TAGS

ALL DIMENSIONS IN MILLIMETRES
TOLERANCES:
WHOLE NUMBER ± 1
ONE DECIMAL ± 0.5
ANGULAR $\pm 0.5^\circ$

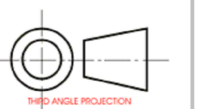

DRAWN BY: DANIEL MCCARRON

SCALE: 1:10 A3

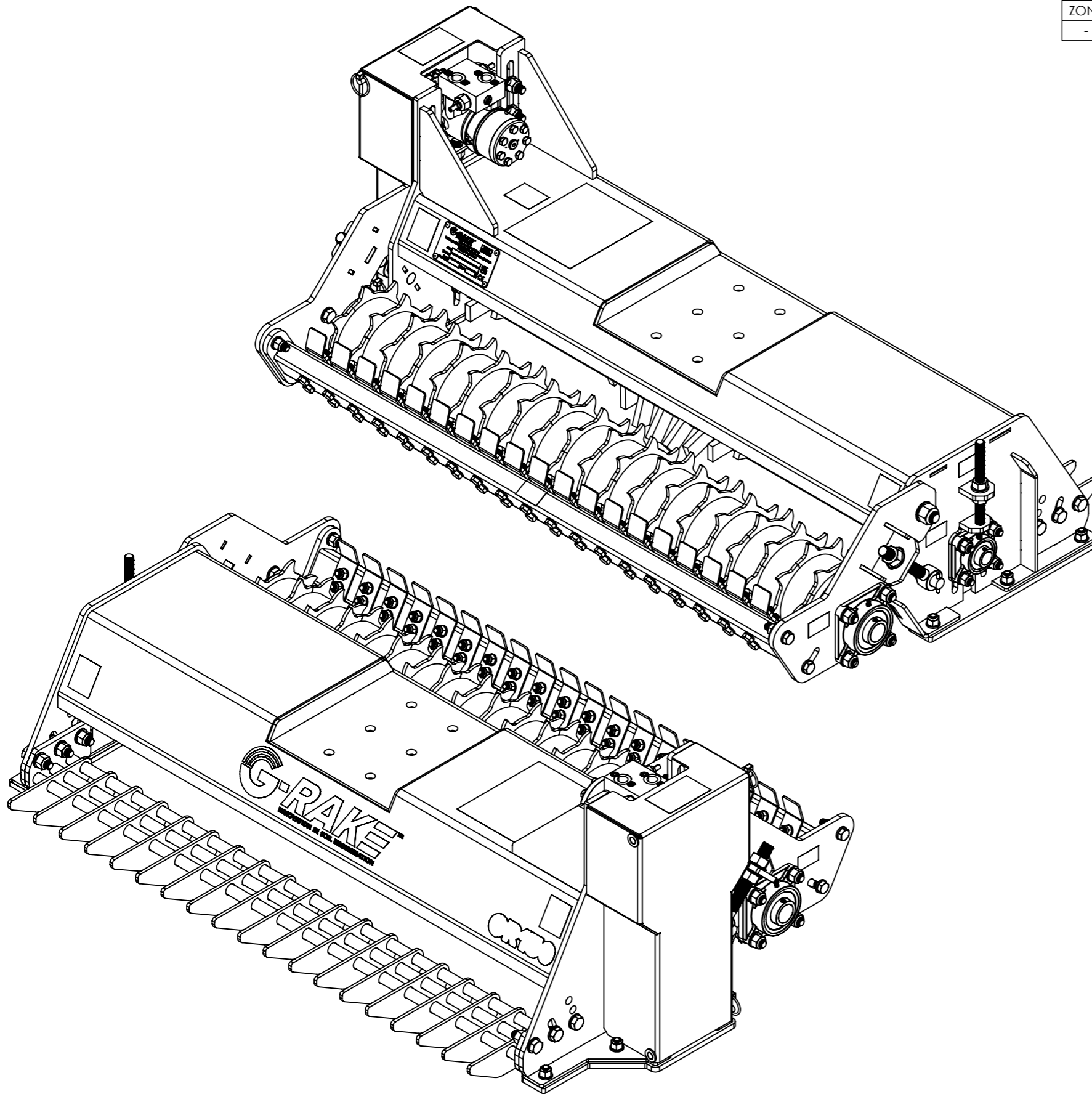

REVISIONS				
ZONE	REV.	DESCRIPTION	DATE	APPROVED
-	-	See Sheet1	-	-

ITEM NO.	PART NUMBER	DESCRIPTION	QTY.
1	GR-1001_120	Main Frame 120	1
2	GR-1002	Rear Arm LHS	1
3	GR-1003	Rear Arm RHS	1
4	GR-1004_120	Front Rake 120	1
5	GR-1005_120	Motor Roller 900	1
6	GR-1006_120	Rear Roller 120	1
7	GR-1007_120	Rear Box Crossmember 120	1
8	GR-1009	Motor Roller Adjuster LHS	1
9	GR-1010	Chain Casing	1
10	GR-1011	Motor Plate	1
11	GR-1012	Chain Casing Pin Long	1
12	GR-1013	Chain Casing Pin Short	1
13	GR-1014	Motor Roller Adjuster RHS	1
14	GR-033	Bolt On Skid Plate LHS	1
15	GR-034	Bolt On Skid Plate RHS	1
16	GR-035	Rear Roller Wear Plate	19
17	MP125CD with Relief Valve		1
18	M16 Washer	BZP	5
19	M16 Nyloc Nut	BZP	1
20	25mm 4 Bolt Flanged Bearing	UCF205	2
21	35mm 4 Bolt Flanged Bearing	UCF207	2
22	M10 Washer	BZP	76
23	M10 Nyloc Nut	BZP	38
24	M10x65mm Hex Head Bolt	BZP	38
25	M12 Nyloc Nut	BZP	22
26	M12 Washer	BZP	36
27	M12x55mm Hex Head Bolt	BZP	8
28	M12x50mm Hex Head Bolt	BZP	6
29	M12x35 Countersunk Bolt	BZP	8
30	M14 Washer	BZP	36
31	M14 Nyloc Nut	BZP	18
32	M14x50mm Hex Head Bolt	BZP	18
33	M16 Nut	BZP	4
34	M20x200mm Eyebolt	BZP	2
35	M20 Washer	BZP	12
36	M20 Nyloc Nut	BZP	2
37	M20 Nut	BZP	4
38	ASA60H-1	Heavy Duty Chain	1
39	61-15 Sprocket, 1610-25 Taper Bush		2
40	ASA60H-1-CL	Connection Link	1
41	4.5x42mm Linch Pin	YZP	2
42	5x40mm Slotted Spring Roll Pin	Spring Steel	2
43	G-Rack Serial Plate		1
44	4.8x12mm Aluminum Steel Dome Head Rivet	Grip Range: 6.5 - 8.5mm	4
45	7x8x32mm Rounded Machine Keyway	BB-381031	1
46	M6x1mm 45 Degree Grease Nipple	Steel Zinc Plated	2
47	M6x1mm Straight Grease Nipple	Steel Zinc Plated	2
48	G-Rake Sticker		1
49	GR120 Sticker		1
50	Check Nuts and Bolts Regularly Sticker		1
51	Do Not Remove Shield, Turning Chains, Oil Chain Regularly & Check Chain Tension Sticker		1
52	Grease Regularly Sticker		3
53	Keep a Safe Distance & Rotating Shaft Sticker		4
54	Keep a Safe Distance Sticker		1
55	Operator Instructions & Max Oil Flow Sticker		1
56	Turning Chains & Check Nuts Sticker		1



G-RAKE LIMITED
 7 SLIEVEGRANE ROAD, DOWNPATRICK,
 NORTHERN IRELAND, BT30 6PF
TELEPHONE: 02844617777
EMAIL: INFO@G-RAKE.CO.UK

PRODUCT:
G-RAKE

PART NUMBER:
GR120

FINISH:
SEE PART AND ASSEMBLY
DRAWINGS

SERIAL NUMBER:
GR120XXXX

MATERIAL:
SEE PART DRAWINGS

DO NOT SCALE DRAWING
 DEBUR/BREAK SHARP EDGES
 REMOVE LASER/FOLDING TAGS

ALL DIMENSIONS IN MILLIMETRES
 TOLERANCES:
 WHOLE NUMBER ±1
 ONE DECIMAL ±0.5
 ANGULAR ±0.5°

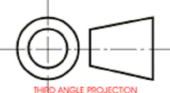

DRAWN BY: DANIEL MCCARRON

SCALE:1:8 A3